

# INVESTMENT CASTING BALL VALVE

## V-1

- Investment Castings for Body and Cap
- Threaded ends: ANSIB2.1,BS21,DIN259/2999
- Internal entry blow-out proof stem
- Pressure rating: 1000PSI(PN63)
- Material: CF8M,CF8,CF3M,WCB
- Pressure test: API598

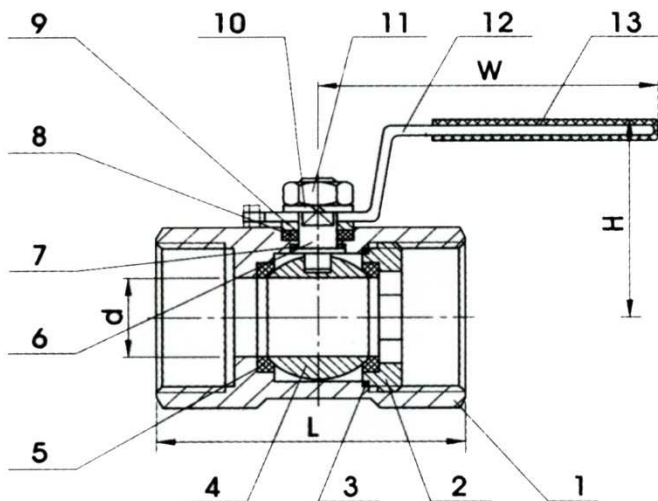
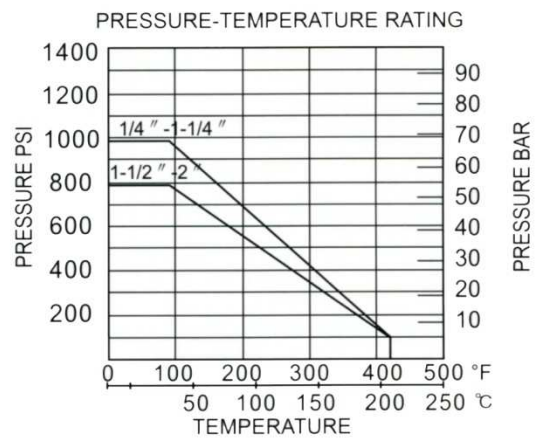

ITEM	PART	MATERIAL	QTY.
1	Body	CF8M(1.4408)	1
2	Cap	CF8M(1.4408)	1
3	Body Gasket	PTFE	1
4	Ball	SS316	1
5	Ball Seat	R-PTFE(15%)	2
6	Stem	SS316	1
7	Thrust Washer	PTFE	1
8	Stem Packing	PTFE	1
9	Washer	SS304	1
10	Spring Washer	SS304	1
11	Nut	SS304	1
12	Handle	SS304	1
13	Handle Cover	Plastic	1

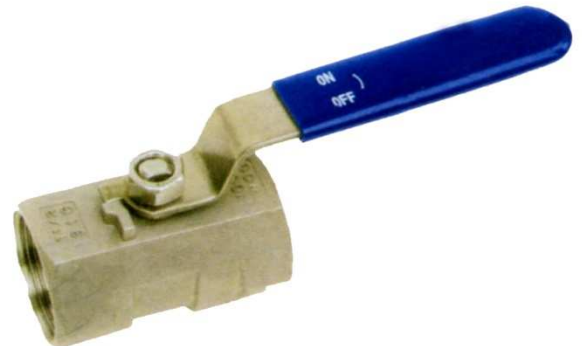

### V-1 Specifications

SIZE	d	L	H	W	TORQUE(N·m)	WEIGHT(Kgs)
1/4 "	5	40	33	67	2	0.07
3/8 "	7	45	36	67	2	0.10
1/2 "	9	65	37	93	3	0.16
3/4 "	12.5	60	42	93	3	0.25
1 "	15	71	52	103	4	0.40
1-1/4 "	20	78	56	103	5	0.65
1-1/2 "	25	82	65	125	7	0.83
2 "	32	100	70	125	9	1.30



### ERAWAN TECH CO.,LTD.

43/9 Soi Sukhumvit 103, Sukhumvit Rd., Bangna, Bangkok 10260 Thailand

Tel : 02-747-5517 [AUTO], Fax : 02-747-5514, 02-399-4427

Website : [www.erawantech.co.th](http://www.erawantech.co.th) E-mail : [erawantech1@yahoo.com](mailto:erawantech1@yahoo.com)